

1. CAUTIONARY NOTES FOR SAFE USE OF THE PRODUCT

For the correct use of this product, read through this manual before use. The following safety symbol is indicated on the product to ensure safe use.



If this symbol is indicated on the product, the operator should refer to the explanation given in the instruction manual in order to avoid personnel injury or death to either themselves or other personnel, and/or damage to the instrument. The manual describes the special care the operator should exercise to avoid shock or other dangers that may result in injury or loss of life.

The following symbol marks are used only in this manual.



IMPORTANT

Indicates that operating the hardware or software in a particular manner may damage it or result in a system failure.



NOTE

Draws attention to information that is essential for understanding the operations and/or features of the product.

2. CHECKING PRODUCT SPECIFICATIONS AND THE CONTENTS OF PACKING

(1) Model Number and Specification Check

Check that the model number and specifications shown on the nameplate attached on the side of the product are as ordered.

(2) Contents of the Packing

Check that the packing contains the following items:

- VJQ7 main unit, 1
- Instruction Manual (IM 77J01Q17-01E), 1

Accessories:

- Tag number label, 1
- Range label, 1
- Shunt resistor (for specification of current input), 1

3. GENERAL

The VJQ7 is a plug-in analog/pulse Transmitter that converts DC current or DC voltage signal into isolated transistor-contact pulse or contactless AC switch pulse.

The VJQ7 converter features:

- Either pulse output, communication function (RS-485), or alarm output (2 relay contacts) is selectable as Output-2.

Keep this manual in a safe place.

4. MOUNTING METHODS

4.1 Wall Mounting

Loosen the main unit-fixing screw of the transmitter to disconnect the main unit from the socket. Next, anchor the socket onto the wall with screws. Then, plug the main unit into the socket and secure the main unit with the main unit-fixing screw.

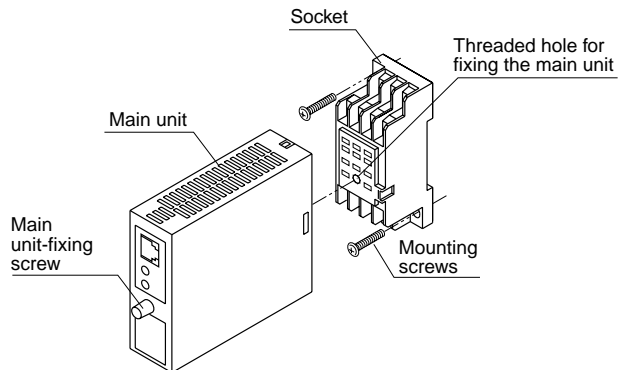

Fig. 4.1

4.1.1 Mounting Dimensions

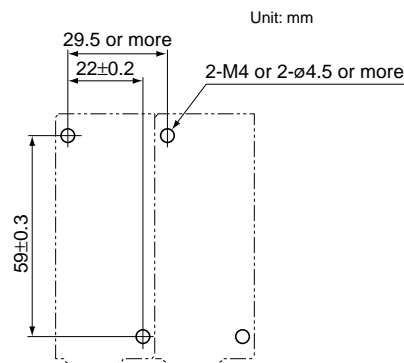

Fig. 4.2

4.2 DIN Rail Mounting

Locate the transmitter so that the DIN rail fits into the upper part of the DIN-rail groove at the rear of the socket, and fasten the socket using the slide lock at the lower part of the socket.

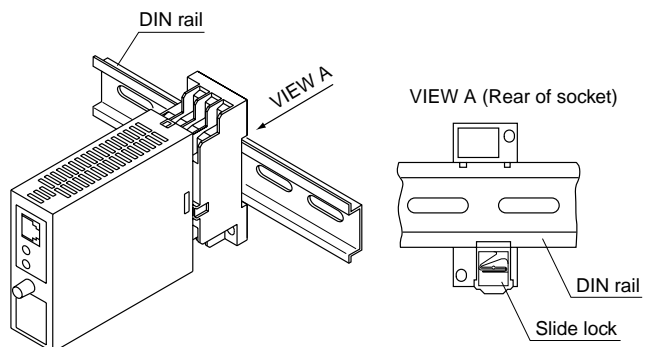

Fig. 4.3

4.3 Mounting Using a Multi-mounting Base

For mounting using a multi-mounting base, see the Instruction Manual for VJCE (VJ Mounting Base).

4.4 Using Ducts

Wiring ducts should be installed at least 30 mm away from the top or bottom of the main unit.

4.5 In case of top-and-bottom close mounting

Transmitter should be mounted horizontally with its top and bottom slits being vertical. The top and bottom slits should not be covered.

The area for wiring is required above and below the transmitter (the area with slant lines).

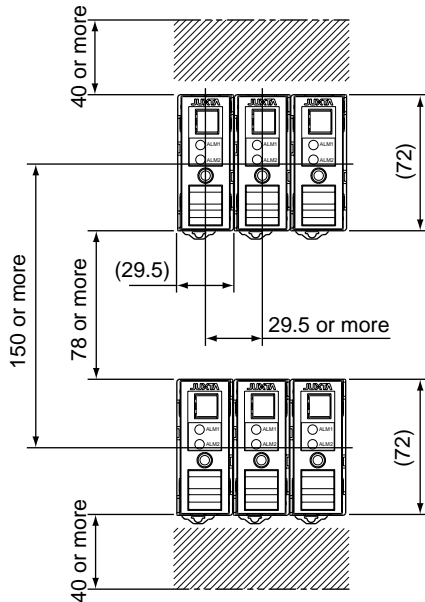

Fig. 4.4

5. INSTALLATION LOCATION

- For installation, avoid any location where the product may be subject to vibrations, corrosive gases, or large amounts of dust, or where the product is exposed to water, oil, solvents, direct sunlight, radioactive rays, or strong electric or magnetic fields.
- If there is a possibility that lightning could induce a high surge voltage on the power and signal lines, provide lightning arresters on the line between the field instrument and indoor instrument in order to protect the product. Install a dedicated arrester on the field side and another on the indoor side.

6. EXTERNAL WIRING



WARNING

Turn OFF the power supply and make sure that none of the cables are not in the hot-line state before carrying out the wiring to avoid the possibility of electric shock.

Wires are connected to the terminals of the isolator's socket. M3 screw terminals are provided for the connection of external signals. Attach a crimp-on lug to each wire for connection to the terminals.

- Recommended cables: A nominal cross-sectional area of 0.5 mm² or thicker for signal cables, and that of 1.25 mm² or thicker for power cables, and shielded twisted-pair cables (AWG24) for communication wiring cables.

- For mounting, use M3 screws and crimp-on terminals with insulating sleeves appropriate for the wires used. Tool of the crimp-on terminals to be used should be appropriate for the crimp-on terminals.
- Mount a breaker on the external place. Mount a switch or 5A circuit breaker on the place near by the instrument, within operator's reach. And attach the indication that it is for disconnecting the instrument.

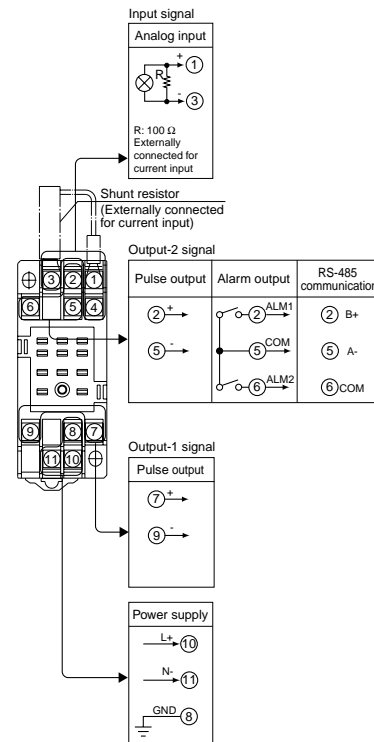

Fig. 6.1



NOTE

- The use of inductance (L) loads such as auxiliary relays and solenoid valves causes malfunction or relay failure; always insert a CR filter or diode for spark-removal into the line in parallel with the load.
Recommended CR
C: 0.5 to 1μF against contact current 1A
R: 0.5 to 1 Ω against contact voltage 1V
- Keep all sources of noise away from the power and signal cables. Otherwise, accuracy cannot be assured.
- Provide grounding to a grounding resistance of 100 Ω. The length of the grounding cable should be 20 m or less. Directly connect the lead from the ground terminal (terminal no. 8) of the isolator to the ground. Do not carry out daisy-chained inter-ground terminal wiring.
- Direct Current
- “Overvoltage category (Installation category)” describes a number which defines a transient overvoltage condition. It implies the regulation for impulse withstand voltage. “II” applies to electrical equipment which is supplied from the fixed installation like distribution board.
- “Pollution degree” describes the degree to which a solid, liquid, or gas which deteriorates dielectric strength or surface resistivity is adhering. “2” applies to normal indoor atmosphere. Normally, only non-conductive pollution occurs. Occasionally, however, temporary conductivity caused by condensation must be expected.
- Rated fuse of 125VDC, 1A is stored. However, operators can not replace the fuse.



IMPORTANT

- If this instrument is used in a manner not specified in this manual, the protection provided by this instrument may be impaired.
- If the product is operated by a power supply exceeding the specifications, the product may become extremely hot and, as a result, damaged. To prevent this, ensure the following before turning on the power.
 - (a) The voltage of the supplied power and the input signal level meet the specifications of the product.
 - (b) External wires are connected to the correct terminals (refer to Chapter 5).
- Do not operate the product in the presence of flammable or explosive gases or vapors. To do so is highly dangerous.
- The product is sensitive to static electricity; exercise care in operating it. Before you operate the product, touch a nearby metal part to discharge static electricity.

7. DESCRIPTION OF FRONT PANEL AND CONNECTION OF SETTING TOOLS

7.1 Front Panel

The communications connector in the front panel is used for setting up parameters through a PC (VJ77 PC-based Parameters Setting Tool) or the Handy Terminal. The ALM1 and ALM2 LEDs light up if an alarm occurs (those LEDs are provided only when the output-2 is specified for alarm output.)

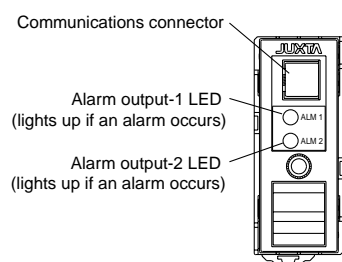

* The LEDs are provided only when output-2 is specified for alarm output.

Fig. 7.1 Front Panel

7.2 Connecting the Setting Tools

Connect the modular jack-to-connector adapter (E9786WH) to the JUXTA communication cable with 5-pin connector (F9182EE) and then connect this adapter to the communication connector of JUXTA.

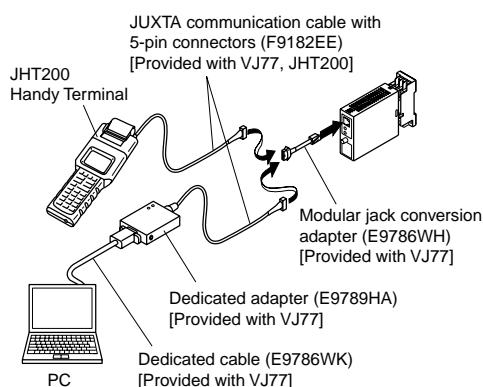

Fig. 7.2 Connecting the Setting Tools

8. SETTING PARAMETERS

Set the parameters using a PC (VJ77 PC-based Parameters Setting Tool) or the Handy Terminal. Refer to the list of parameters in this manual and the Instruction Manual for Handy Terminal (IM JF81-02E) and VJ77 PC-based Parameters Setting Tool (IM 77J01J77-01E).

8.1 Settings Related to Inputs and Outputs

8.1.1 Input Type

Set by selecting input type from among VOLTS (DC voltage) and CURRENT (DC current) in D16: INP TYPE.

8.1.2 Input Hard Range

Set by selecting the input hard range from among AUTO, HIGH, MIDDLE, and LOW in D17: SELECT RANGE. Generally, select AUTO.

- AUTO: Sets the input hard range automatically with respect to the input range to be set.
- HIGH: For a span of 5 V or more in an input range of -10 to +10 V
- MIDDLE: For a span of 2.5 V or more in an input range of -5 to +5 V
- LOW: For a span of 0.5 V or more in an input range of -1 to +1 V



NOTE

The conditions for the input hard range (HIGH, MIDDLE, and LOW) are specified for operations within the range of accuracy rating. The input range may be set to a range not meeting these conditions, but take note of accuracy limitations. Similar accuracy limitations exist even when AUTO is selected. For more information on accuracy limitations, see the general specifications of VJQ7 (GS 77J1Q17-01E).

8.1.3 Input Range

Set the 0% value of input range to D22: INPUT1 L_RANGE and the 100% value of input range to D23: INPUT1 H_RANGE within the numerically specified range.

8.1.4 Output Range Unit

When referring and setting the output range, select and set Hz or kHz in D10: UNIT.

8.1.5 Output Range

Set the 0% value of output range in D24: OUT L_RNG, and 100% of output range in D25: OUT H_RNG within the numerically specified range.

8.1.6 Pulse Width Type

Select and set "50%" (duty 50%), "ON PULSE" (ON-state pulse width fixed), or "OFF PULSE" (OFF-state pulse width fixed) in D46: PULSE TYPE.

8.1.7 Pulse Width Time

The pulse width time is set when the pulse width type is set to "ON PULSE."

Select and set the numerical value in D43: PULSE WIDTH.

Pulse width setting range: 0.1 to 500ms, by 0.1ms

The output frequency when ON-state pulse width or OFF-state pulse width is fixed is as follows. The frequency over the following frequency is limited.

$$\frac{1}{\text{Pulse width set value(ms)} \times 2} \times 1000[\text{Hz}]$$

8.2 Settings Related to Communication Function

Set the following parameters when output-2 is specified for communication function. For more information on the communication function, see the Instruction Manual for VJ Series Communication Function (IM 77J1J11-01E).

8.2.1 Communication Protocol

Set the communication protocol by selecting from among PC-LINK, PC-LINK WITH SUM, MODBUS ASCII, MODBUS RTU, and LADDER in F01: PROTOCOL.

8.2.2 Communication Address

Set the address number of the isolator numerically in a range of 1 to 99 in F02: ADDRESS.

8.2.3 Baud Rate

Set the baud rate by selecting from among 1200, 2400, 4800, and 9600 bps in F03: BAUD RATE.

8.2.4 Parity

Select and set NONE, EVEN, or ODD in F04: PARITY.

8.2.5 Data Length

Select and set 7 bits or 8 bits in F05: DATA LEN.

8.2.6 Stop Bit

Select and set 1 bit or 2 bits in F06: STOP BIT.

8.2.7 Input Decimal Point Position

Number of digits of decimal places can be set.

Select and set among 0 to 5 digits in F07: INPUT DEC PT.

8.3 Settings Related to Alarm Output

Set the following parameters when output-2 is specified for alarm output.

8.3.1 Alarm Setpoints

Set the alarm setpoints of alarm-1 and alarm-2 in E03: SET POINT1 and E04: SET POINT2 numerically.

- Setting range: A range of 0 to 100% of input range
- Setting resolution: 0.1%

8.3.2 Direction of Alarm Action

Select the direction of alarm-1 action and that of alarm-2 action from among HIGH ALM (high-limit alarm) and LOW ALM (low-limit alarm) and set each in E05: ALM1 ACTION (direction of alarm-1 action) or E06: ALM2 ACTION (direction of alarm-2 action).

- To activate alarm status when input signal \geq alarm setpoint, select HIGH ALM.
- To activate alarm status when input signal \leq alarm setpoint, select LOW ALM.

8.3.3 Hysteresis

Set alarm-1 and alarm-2 hysteresis, in E09: HYSTERESIS1 and E10: HYSTERESIS2. Hysteresis is a value added to the alarm setpoint in order for an alarm status to be released (to normal) after the alarm status has been activated. The alarm status will be released in the following conditions, depending on the direction of alarm action.

- * When HIGH ALM (high-limit alarm) is set: Alarm is released when input signal $<$ (alarm setpoint - hysteresis).
- * When LOW ALM (low-limit alarm) is set: Alarm is released when input signal $>$ (alarm setpoint + hysteresis).
- Setting range: A range of 0 to 100% of input range
- Setting resolution: 0.1%

8.3.4 Alarm ON Delay and Alarm OFF Delay

Set alarm-1 and alarm-2 ON delays in E11: ON DELAY1 and E12: ON DELAY2 and then alarm-1 and alarm-2 OFF delays in E13: OFF DELAY1 and E14: OFF DELAY2.

An alarm ON delay is a delay time from the establishment of alarm condition to alarm output; an alarm OFF delay is a delay time from the establishment of return-to-normal condition to output.

- Setting range: 0 to 999 seconds
- Setting resolution: 1 second (Note that about 0.2 second will be added to set time to prevent erroneous operation.)

For example, when an alarm ON delay is set to 1 second, alarm output is generated if alarm status continues for more than 1 second after the input value exceeds the alarm setpoint. Further, when an alarm OFF delay is set to 2 seconds, alarm output is released if normal condition continues for more than 2 seconds after the input value has returned to normal from the alarm status.

8.3.5 Direction of Relay Action

Set the direction of relay energizing in alarm-1 normal condition and alarm-2 normal condition by selecting from among NRM DE-ENERGIZED (de-energized under normal condition) and NRM ENERGIZED (energized under normal condition) in E15: RL1 ACTION and E16: RL2 ACTION and set them.

9. DESCRIPTION OF ALARM ACTIONS

This chapter describes examples of alarm actions under the following conditions.

Item	Alarm-1		Alarm-2	
	Parameter	Setpoint	Parameter	Setpoint
Direction of alarm action	E05:ALM1 ACTION	High-limit alarm	E06:ALM2 ACTION	Low-limit alarm
Alarm setting	E03:SET POINT1	80%	E04:SET POINT2	15%
Hysteresis	E09:HYSTERESIS1	10%	E10:HYSTERESIS2	5%
Alarm ON delay	E11:ON DELAY1	1 sec.	E12:OFF DELAY2	3 sec.
Alarm OFF delay	E13:OFF DELAY1	2 sec.	E14:OFF DELAY2	4 sec.
Description of alarm actions	The alarm sounds if the condition where the input value is 80% or more of high-limit alarm continues for more than 1 second. After the alarm sounds, when the condition where input value is less than 70% of the high-limit alarm continues for more than 2 seconds, the status returns to normal.		The alarm sounds if the condition where the input value is 15% or less of low-limit alarm continues for more than 3 seconds. After the alarm sounds, when the condition where input value is more than 20% of the low-limit alarm continues for more than 4 seconds, the status returns to normal.	

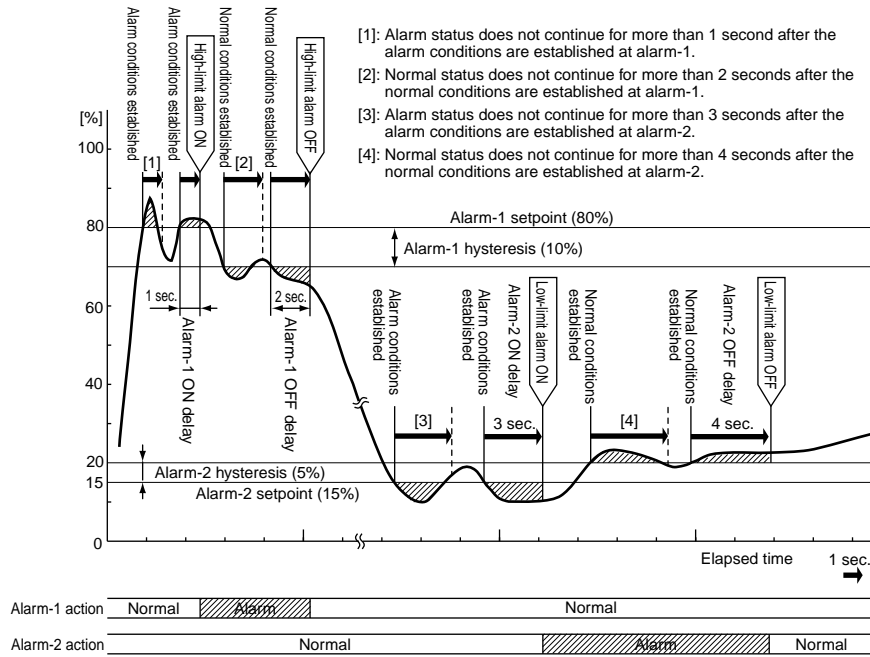

10. LIST OF PARAMETERS

No.	Item	Display	Remark	No.	Item	Display	Remark
01	Model	MODEL					
02	Tag no.	TAG NO					
03	Self-check result	SELF CHK					
Display items							
A	Display1	DISPLAY1		B	Display2	DISPLAY2	
A01	Input value	INPUT1		B01	Input value	INPUT1	
A02	Output value	OUTPUT		B02	Output value	OUTPUT	
A07	Alarm-1 status	ALM1 STATUS		B07	Alarm-1 status	ALM1 STATUS	
A08	Alarm-2 status	ALM2 STATUS		B08	Alarm-2 status	ALM2 STATUS	
A54	Status	STATUS	*1	B60	Self-check result	SELF CHK	
A56	Rev. no	REV NO		*1: The Status is displayed for service personnel to see history records.			
A58	Menu rev.	MENU REV					
A60	Self-check result	SELF CHK					
Setting items							
D	Setting (I/O)	SET(I/O)		E	Setting (alarm output)	SET(ALM)	
D01	Tag no. 1	TAG NO.1		E03	Alarm-1 setting	SET POINT1	
D02	Tag no. 2	TAG NO.2		E04	Alarm-2 setting	SET POINT2	
D03	Comment 1	COMMENT1		E05	Direction of alarm-1 action	ALM1 ACTION	
D04	Comment 2	COMMENT2		E06	Direction of alarm-2 action	ALM2 ACTION	
D10	Output range unit	UNIT		E09	Alarm-1 hysteresis	HYSTERESIS1	
D14	Low output cut point	LOW CUT		E10	Alarm-2 hysteresis	HYSTERESIS2	
D16	Input type	INP TYPE		E11	Alarm-1 ON delay setting	ON DELAY1	
D17	Selection of input hard range	SELECT RANGE		E12	Alarm-2 ON delay setting	ON DELAY2	
D18	Input resistance	IN RESIST		E13	Alarm-1 OFF delay setting	OFF DELAY1	
D22	Input low range	INPUT1 L_RNG		E14	Alarm-2 OFF delay setting	OFF DELAY2	
D23	Input high range	INPUT1 H_RNG		E15	Direction of alarm-1 relay action	RL1 ACTION	
D24	Output low range	OUT L_RNG		E16	Direction of alarm-2 relay action	RL2 ACTION	
D25	Output high range	OUT H_RNG		E60	Self-check result	SELF CHK	
D46	Pulse width type	PULSE TYPE		F	Setting (communication)	SET(COM)	
D47	Pulse width time	PULSE WIDTH		F01	Communication protocol	PROTOCOL	
D60	Self-check result	SELF CHK		F02	Address	ADDRESS	
There are items not displayed depending on what output-2 is specified.				F03	Baud rate	BAUD RATE	
				F04	Parity	PARITY	
				F05	Data length	DATA LEN	
				F06	Stop bit	STOP BIT	
				F07	Decimal point position of input	INPUT DEC PT	
				F60	Self-check result	SELF CHK	
				Adjusting items			
P	Adjustment	ADJUST		Q	Test	TEST	
P02	Zero adjustment of input-1	ZERO ADJ		Q04	Forced output (alarm)	ALM1 TEST	
P03	Span adjustment of input-1	SPAN ADJ1		Q05	Forced output (alarm)	ALM2 TEST	
P17	Adjustment of external input resistance	RESISTOR ADJ		Q08	Forced output	OUT TEST	
P60	Self-check result	SELF CHK		Q60	Self-check result	SELF CHK	

11. MAINTENANCE

The product starts running immediately when the power is turned on; however, it needs 10 to 15 minutes of warm-up before it meets the specified performance.

For cleaning the instrument, use a soft and dry cloth.

11.1 Calibration Apparatus

- Voltage/current generator (Yokogawa 7651 or the equivalent): 1
- A counter (Yokogawa TC100 or the equivalent) or oscilloscope (Yokogawa DL1540 or the equivalent): 1
- A resistor (1k Ω , 1.6k Ω): 1 each
- 6V battery: 1

11.2 Calibration Procedure

Connect the instruments as shown in Fig.11.1. First adjust the output-1 signal and then the output-2 signal.

Produce input signals equivalent to 0, 25, 50, 75 and 100% of the input span to the converter from the voltage and current generator. Then, check that the converter's output signal shows the outputs corresponding to 0, 25, 50, 75, and 100% of the input span within the rated accuracy range. Take the same calibration procedure for the output-2, and confirm that the frequency of the output 2 is the same as that of the output 1.

When using a oscilloscope, the wave shaping of output pulse can be confirmed.

If the output signal is out of the rated accuracy range, adjust the output signal level using the Handy Terminal (JHT200). For adjustment, refer to Instruction Manual for VJ77 Parameters Setting Tools (IM 77J01J77-01) or for Handy Terminal (IM JF82-01).

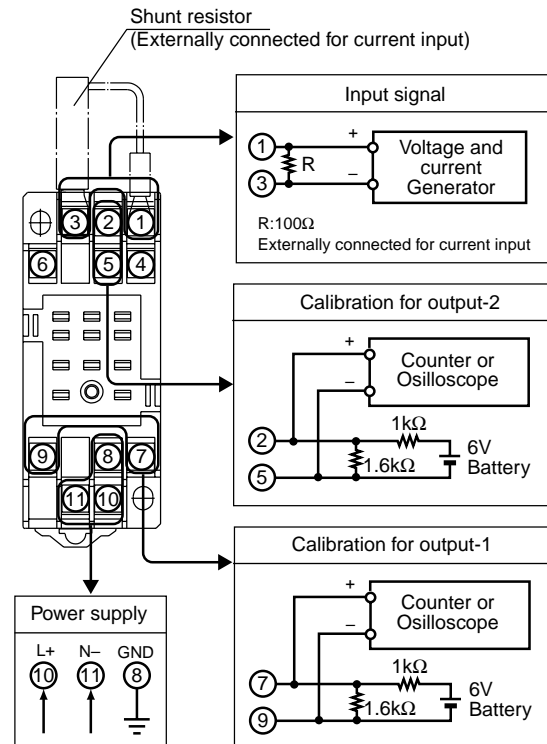

Fig. 11.1